

ENGLISH

**NA-11UT Series
INSTRUCTION MANUAL**

CONTENTS

1. Brief introduction	1
2. Mainspecifications	1
3. Installing the oil pan	1
4. Installing the machine head	2
5. Installing the knee lifter assy	2
6. Adjusting the knee lifter	3
7. Lubrication	3
8. Test operation	4
9. Installing the needle	5
10. Removing the bobbin case	5
11. Winding the bobbin thread	5
12. Threading the bobbin thread	6
13. Threading the needle thread	6
14. Adjusting the stitch length	7
15. Sewing and backtacking	7
16. Adjusting the thread tension	8
17. Adjusting the presser foot pressure	8
18. Adjusting the trailing length after thread trimming	9
19. Adjusting the thread tension spring	9
20. Adjusting the upper thread guide	10
21. Adjusting the presser foot height	10
22. Adjusting the feed dog height	10
23. Adjusting the feed dog angle	11
24. Adjusting the difference of stitch length between the forward and back tacking	11

25. Adjusting the tension release	11
26. Adjusting the timing of needle and feed mechanism	12
27. Adjusting the rotary hook lubrication amount	12
28. Adjusting the height of needle bar and the timing with hook	13
29. Adjusting the oil pump	13
30. Adjusting the lifting amount of presser feet	14
31. Adjusting the trimming mechanism	15
32. Clean	18

1. 机器简介 Brief introduction

NA-11UT 型直驱中厚料上下送料自动剪线平缝机系单直针,采用连杆式送料,连杆挑线机构,旋梭勾线,形成301线迹。

本机采用油泵自动润滑,运转轻滑,噪音低,振动小,特别适用于缝制皮革,帆布,厚重装饰布,织带类织物,如:箱包,汽车坐垫,帐篷,沙发等。

电脑控制的剪线、定针数、定针位功能,准确可靠。
This machine is designed with link type feed mechanism and link lever thread take-up mechanism and full lubrication by pump. It's suitable for sewing leather, canvas and other heavy weight materials, such as suitcase, car seat, tent, sofa, etc. It's reliable and accurate on such functions as thread trimming, needle positioning, etc.

2. 主要技术规格 Main specifications

型 号	NA-11UT
缝 料	中厚料
最高转速	2000针/分
最大针距	8mm
针杆行程	37mm
压脚交互量	3.5-5.5mm
采用机针	DP x 17 23#
压脚提手控	8mm
升高度膝控	16mm
采用旋梭	自动润滑大旋梭
供油方式	全自动供油(仅限旋梭部)
电机功率	750W

Applications	Medium & heavy weight materials
Max sewing speed	2000 s.p.m
Max stitch length	8mm
Needle bar stroke	37mm
Lifting amount of presser foot	3.5-5.5mm
Needle	DPX17 23#.
Presser foot	By hand 8mm
lifting height	By knee 16mm
Hook	Large lubrication hook
Lubrication	Automatic lubrication (hook only)
Motor power	Servo motor

3. 安装油盘 (图1 Installing the oil pan (Fig.1))

1. 将机头防震块 ② (两个) 插进油盘 ① 前方的角内。
 2. 将机头防震块 ③ (两个) 插进油盘 ① 后方的角内。
 3. 水平地将油盘 ④ 嵌在台板的框孔内。
 4. 将两个机壳铰链套 ⑤ 放入台板的凹槽内。
1. Insert the two head cushion ② into the front corners of the oil pan ①;
2. Insert the two head cushion ③ into the back corners of the oil pan ①;
3. Place the oil pan ④ into the cutouts of table;
4. Insert the two rubber cushion ⑤ into the notches of table.

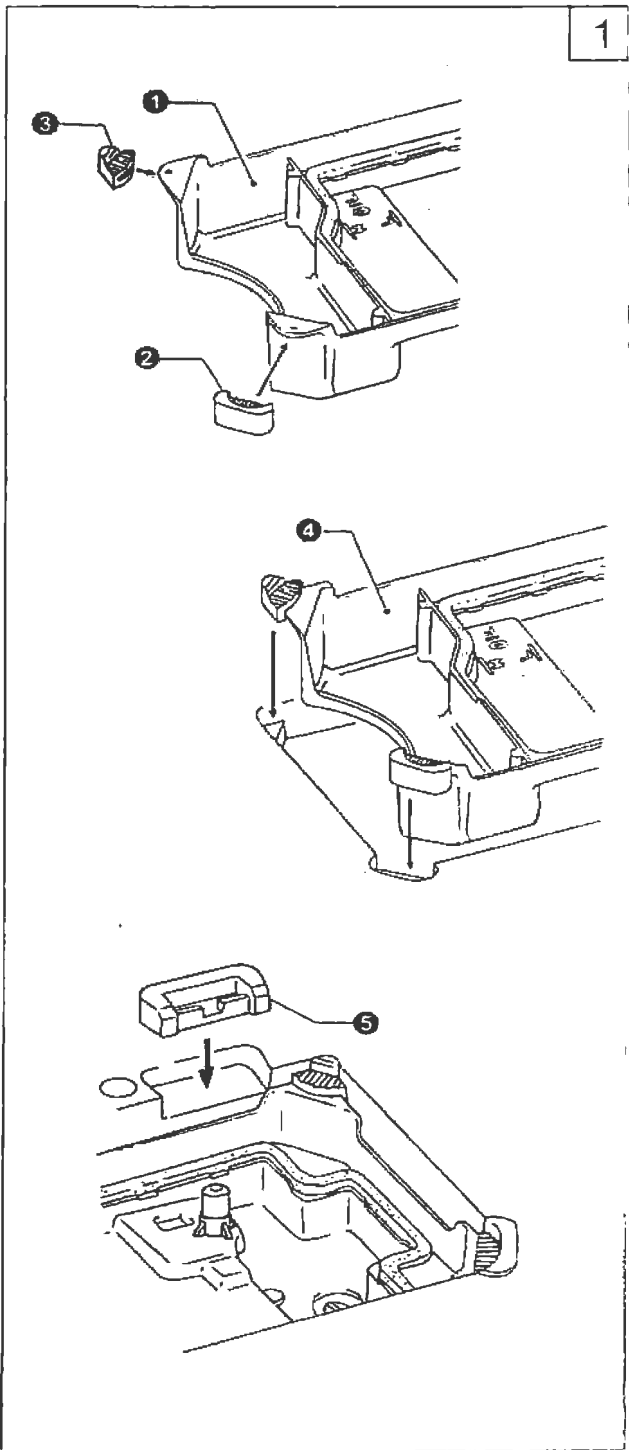

2

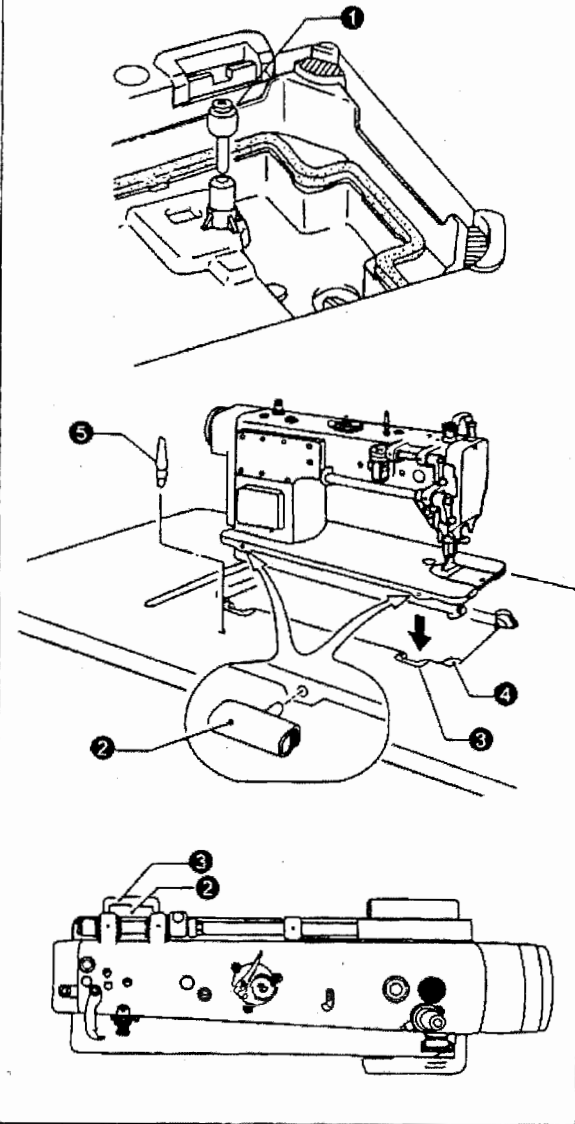

4. 安装机头 (图2) Installing the machine head (Fig.2)

1. 插入膝控提升顶杆 ①。

1. Insert the knee lifter lifting bar ①.

2. 将两个机壳铰链 ② 插入机头平板的两孔内。
2. Insert the two hinges ② into the holes in the machine bed.

3. 将机头上的铰链勾住台板上的铰链套 ③

平稳地将机头放入台板的框孔 ④ 中。

3. Clamp the two hinges onto the rubber cushions ③ in the work table, and then place the machine head onto the head cushions ④ which are on the top of the oil pan corners.

4. 将机头撑杆 ⑤ 插入孔中。

4. Tap the rest bar ⑤ into the table hole.

注意：确保机头撑杆插入孔中。

如撑杆未插到最低位置，放入机头时，机头将发生倾倒，这样比较危险。

NOTE: Tap the rest bar securely into the table hole, if not, the machine head will not be safe when it is tilted back.

3

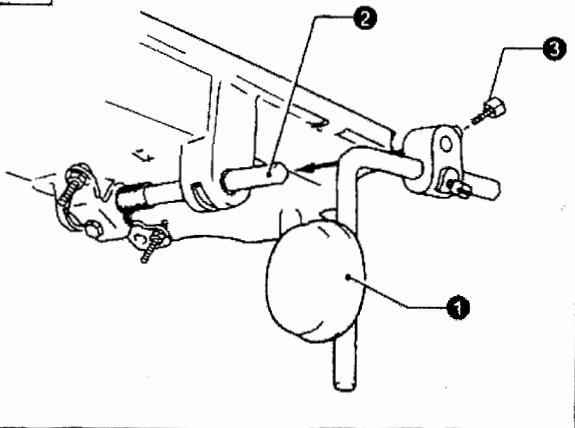

5. 安装膝控装置 (图3) Installing the knee lifter assy. (Fig.3)

将膝控碰块 ①，弯杆及接头插入铰链轴 ② 中，稍微拧紧螺钉 ③。

Insert the knee lifter assy. ① into the shaft ② under the oil pan, and slightly tight the screw ③.

6. 调整膝控装置(图4) Adjusting knee lifter(Fig.4)

1. 转动压脚提升扳手①将压脚②完全放下。
2. 松开螺母③。
3. 拧紧螺钉⑥调节膝控限位架, 使之转动2mm。
4. 拧紧螺母③。
5. 松开螺母⑦。
6. 拧动螺钉⑧, 使该螺钉的末端至膝控限位架之间的长度达到8mm。
7. 通过转动螺钉⑧并操作膝控碰块, 可以使压脚底面至针板的距离在16mm之内得到调整。
8. 调节完成后, 拧紧螺母⑦。

1. Lower the presser foot ② by turning the presser foot bar lifter ①.
2. Loosen the nut ③.
3. Turn the screw ⑥ to adjust the bracket ⑤ to 2mm play.
4. Securely tighten the nut ③.
5. Loosen the nut ⑦.
6. Turn the screw ⑧ until the distance between the end of the screw and bracket is approximately 8mm.
7. Turn the adjusting screw ⑧ to adjust, so that the presser foot is at the desired position within a distance of 16mm above the needle plate when the knee lifter plate ④ is fully pressed.
8. After adjustment, tighten the nut ⑦.

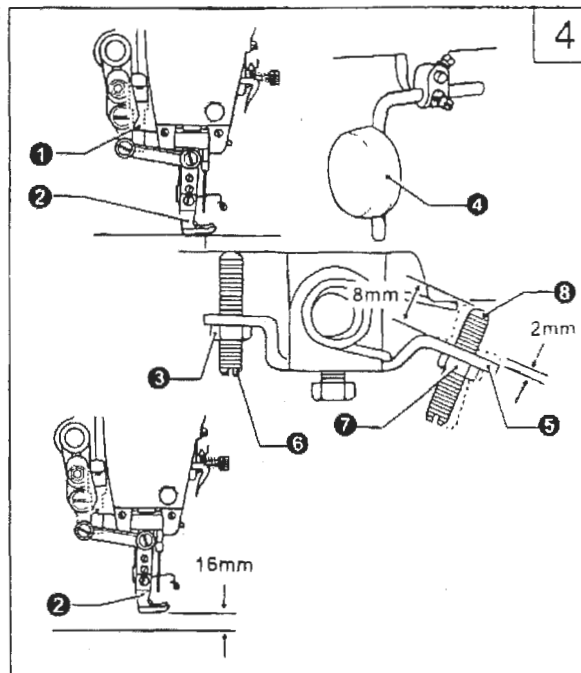

7. 润滑(图5) Lubrication(Fig.5)

1. 油量, 油量必须按油盘内标记加注, 图中标记(A)是油量最高位, (B)是油量最低位。注意油量不得低于标记(B)否则缝纫机各部位就会出现进油停止, 造成发热咬死等情况。
2. 加油, 必须使用18#高速缝纫机油, 运转前油量加至标记(A)。
3. 换油, 1 旋下放油螺钉(C), 排净废油。

新油。2 扫清油盘污尘, 旋紧放油螺钉(C), 加注

1. Oil amount

Please fill the oil according to the mark indicated on the oil pan. Mark (A) means the highest position. Mark (B) means the lowest position. If the oil amount is lower than the Mark (B), oil will not be pumped and machine will be jammed.

2. Fill the oil

Please fill the 18# sewing oil into the oil pan until to the Mark (A)

3. Change the oil

1. Uninstall the screw (C), and drain out the used oil

2. Clean the oil pan, and tighten the screw (C), fill the fresh oil again according the requirement.

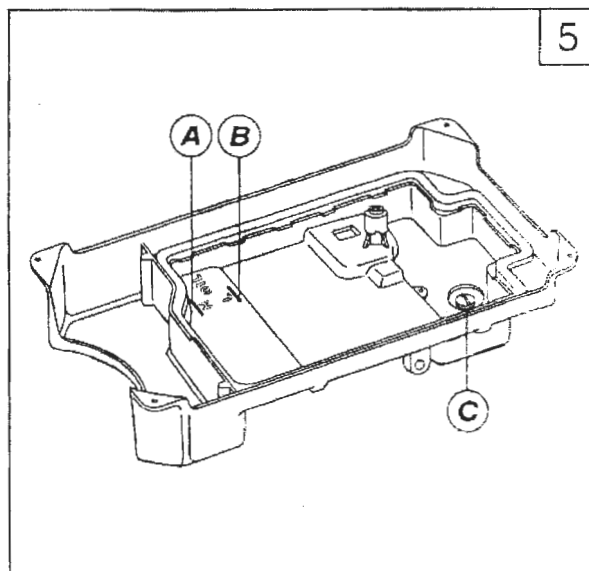

6

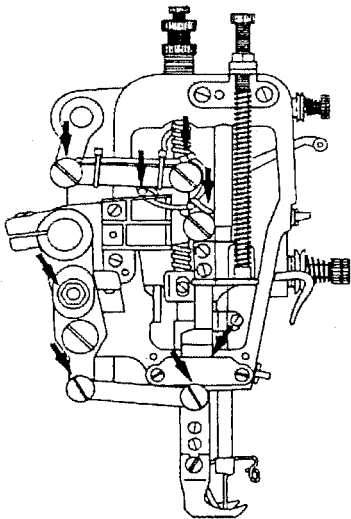
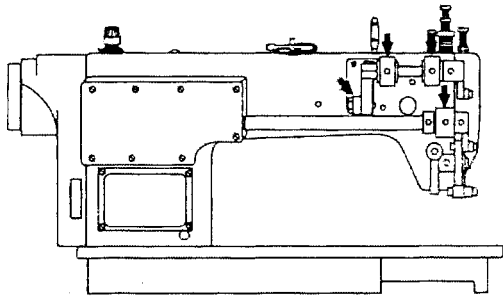
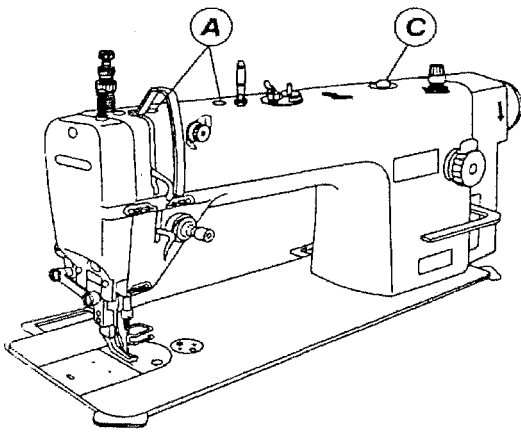

8.试车 (图6) Test operation (Fig. 6)

新机器在开始使用和长期搁置重新使用时, 先卸下机头上部的橡皮塞 (A) 和面板, 按图示的位置充分加油, 然后装上面板, 抬起压脚进行低速运转1000~1500针/分, 并观察油窗 (C) 的喷油情况, 润滑正常后, 仍须保持低速30分钟的运转试验, 以后逐步提高缝纫速度; 经过一个月左右的使用, 使机器充分磨合。然后根据工作的性质再提高到一定缝速。

Carry out the test operation when start up a new sewing machine for the first time, or restart after a long period of non-use.

Remove the rubber cap (A) on the top of the arm and face plate, fully lubricate the parts showed by the arrows.

Install the face plate again, lift the presser foot and operate the machine at a lower speed of 1000-1500spm, and observe the oil running through the oil gauge window.

After one month, then the speed can be increased according to the different sewing operation.

请在图6的A部和箭头部位每天一次左右, 定期进行加油。

Please refuel the parts A and arrows in Fig. 6 on a daily basis.

9. 安装机针 (图7) Installing the needle (Fig. 7)

1. 转动上轮使机针上升至最高位置。
2. 旋松夹针螺钉 ②。
3. 将机针 ③ 直线插入到底 (碰到针杆孔的底部为止), 确保长槽向左, 然后拧紧螺钉 ②。

1. Turn the machine pulley to move the needle bar ① to its highest position;
2. Loosen the screw ②
3. Insert the needle ③ in a straight line as far as it will go, making sure that the long groove on the needle is at the left, and then securely tighten the screw ②

10. 装卸梭芯套 (图8) Removing the bobbin case (Fig. 8)

1. 装梭心套的时候, 机针应该在最高位置。先拉开梭门盖 ①, 之后把梭心套放入旋梭中。放入时请注意梭心套上的定位板是否已经和旋梭心轴上的定位槽相扣合。

2. 卸梭心套时, 必须将梭门套向外扳开并且扳足, 之后捏着扳开的梭门套徐徐地取下梭心套, 如此才能使梭心套钩住梭心, 不让梭心脱落。

1. Turn the machine pulley to lift the needle bar to its highest position. Pull the latch ① of the bobbin case upward and then put the bobbin into the bobbin case, finally insert the complete bobbin case with bobbin into the hook shaft.
2. To remove the bobbin case, pull the latch and draw the bobbin case out of the hook.

11. 绕取梭芯线 (图9) Winding the bobbin thread (Fig. 9)

1. 打开电源。
 2. 将梭芯插入绕线轴 ② 的底部。
 3. 根据箭头所示的方向, 先将线在梭芯上绕几圈。
 4. 扳动绕线摆杆 ③。
 5. 将压脚抬起来。
 6. 踩下踏板, 便开始自动绕底线了。
 7. 当梭芯绕满后, 绕线摆杆 ③ 便会自动复位。
- ★ 如果梭芯线排列不齐, 可以通过松开过线架螺钉 ④ 及移动绕线摆杆 ③ 的位置进行调节。
- ★ 绕线量由满线踏板上的满线度调节螺钉 ⑥ 加以调节。注意: 适当的绕线量为平行绕线至梭芯外径的80%。

1. Turn the power on;
 2. Place the bobbin ① onto the bobbin winder shaft ②;
 3. Wind the thread several circles around the bobbin in the direction indicated by arrow;
 4. Push down the bobbin presser arm ③;
 5. Lift the presser foot;
 6. Depress the treadle, the winding operation will start;
 7. Once finished, the bobbin presser arm ③ will recover automatically.
- ★ If the thread winding is not neat and even, loosen the screw ④ to adjust the position of bobbin winder base.
- ★ Turn the screw ⑥ to adjust the bobbin winding amount
- Tighten the screw to increase the winding amount;
 - Loosen the screw to decrease the winding amount.

Note:
The proper winding amount should be around 80% of the bobbin capacity.

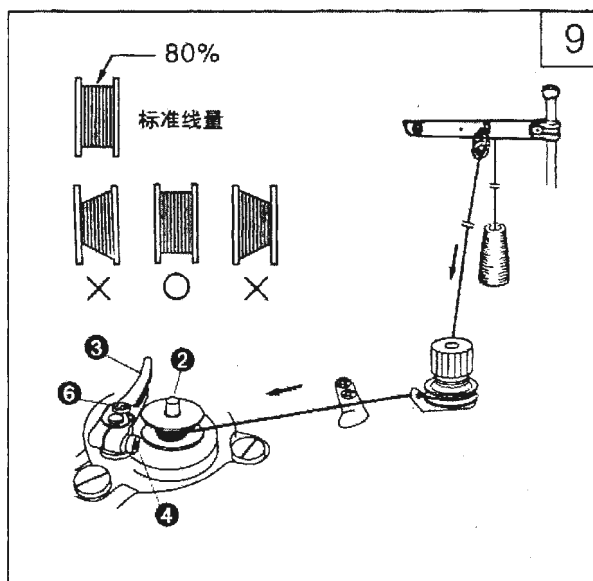
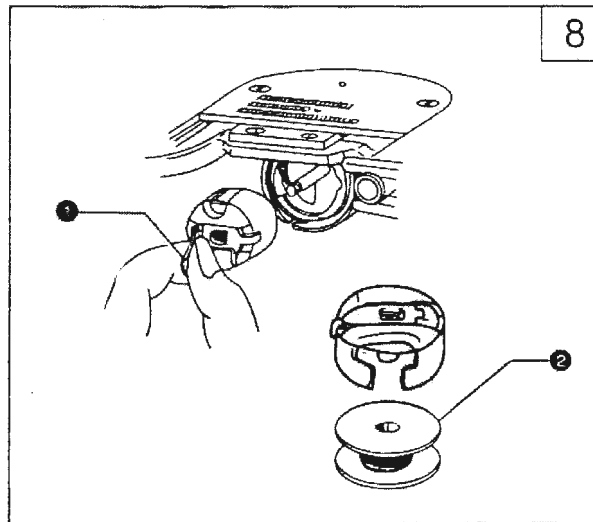
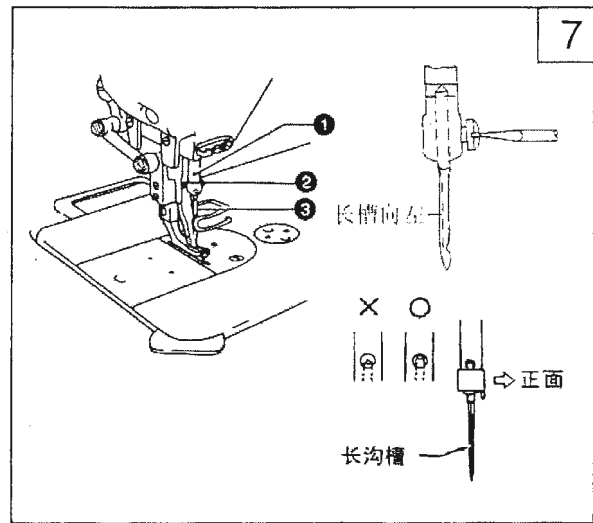

10

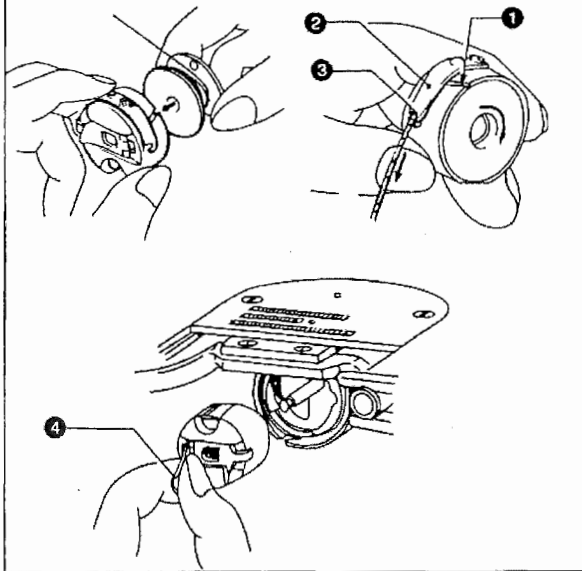

12. 穿底线(图10) Threading the bobbin thread (Fig.10)

1. 转动上轮使机针上升至最高位置。
 2. 梭芯线应为右捻线，然后将梭芯装入梭芯套中。
 3. 捏着线头使其嵌入梭芯套开口槽 ①中，经过梭皮簧 ②顶端叉口 ③中间拉出线头。
 4. 当牵引线时，梭芯应是顺时针转动。
 5. 扳开梭门盖 ④，将梭芯套装入旋梭中（放入时请注意梭芯套上的定位板是否已经和旋梭芯轴上的定位槽相扣合。）
1. Turn the machine pulley to lift the needle to its highest position;
 2. The bobbin thread should be right twist, place the bobbin into the bobbin case;
 3. Pass the thread through the slot ① and spring plate ②, and finally pull it out of the notch ③;
 4. Check that the bobbin should turn clockwise if the thread is pulled;
 5. Hold the latch ④, and place the bobbin case in the hook.

13. 穿面线(图11) Threading the needle thread (Fig.11)

在穿面线之前请让挑线杆上升至最高位置，这样便于穿线并可防止开始缝纫时发生面线从针孔中脱落。
 Raise the thread take-up lever to its highest position. This will make threading easier and will prevent the thread from coming out at the sewing start.

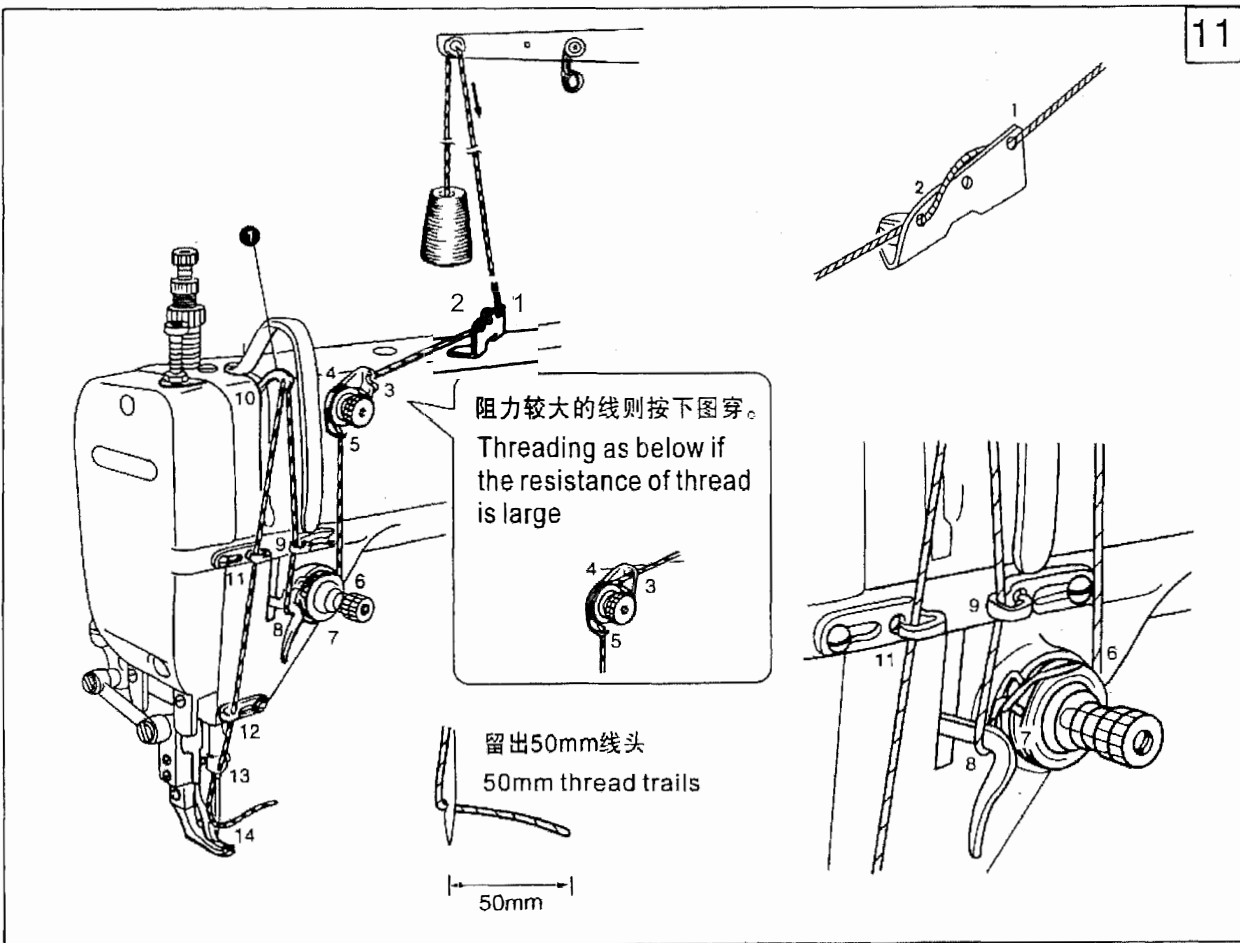

14. 调节针距 (图12) Adjusting the stitch length (Fig.12)

按下针距按键 ②，左右转动针距盘，将针距标盘上的数字对准针距按键 ② 上的竖线标记。

* 数字越大，相应的针距越大。

* 当针距标盘上的数字从大向小方向转动时，将倒缝扳手向下压至一半位置时，转动时更加轻松一些。

While press the stopper ②, turn the stitch length dial ① to make the number on the dial align with the mark on the stopper ②. The number is the stitch length in mm.

* The larger the number, the longer the stitch length will be.

* When turn the dial from a larger setting to a smaller setting, it will be easy to turn if the reverse lever ③ is pressed down.

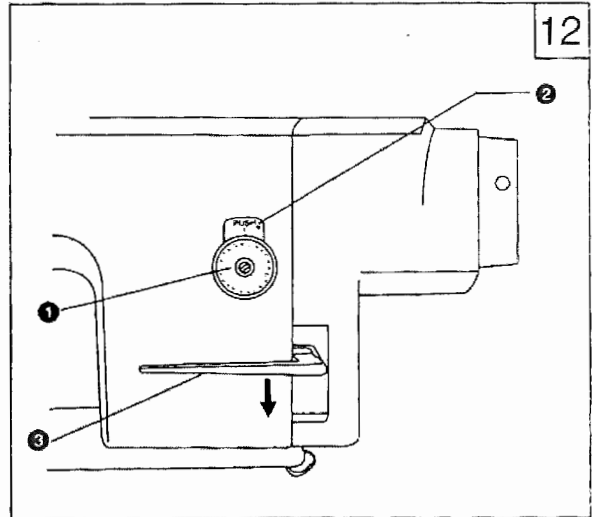

15. 缝纫及倒缝 (图13) Sewing and backtacking (Fig.13)

1. 按下电源开关。

1. Turn the power on;

2. 踩下踏板，缝制开始。

2. Depress the treadle to start sewing.

正常缝制过程中，按下倒缝扳手 ① 或是按下自动倒缝开关，便开始反向送料，放松时，则恢复正常送料。

When the reverse lever ① is pressed or the backtacking button is on during sewing, the feed will be reversed. After release, the feed will recover to normal.

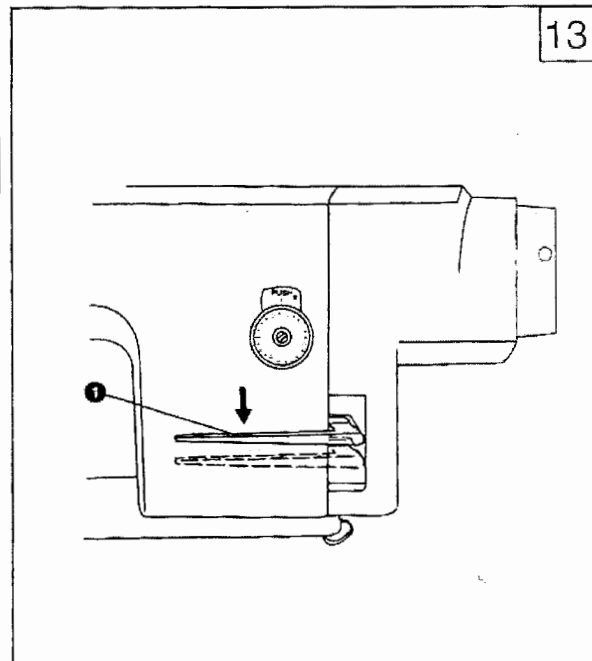

16. 调节线的张力(图14) **Adjusting the thread tension (Fig. 14)**

14

正常线迹 Normal stitch



<p>● 当面线张力太弱时出现的线迹 ● Stitch seam when needle thread tension is too weak</p>	<p>→ ● 增大面线张力 ● increase the needle thread tension → ● 减弱底线张力 ● decrease the bobbin thread tension</p>
<p>● 当面线张力太强时出现的线迹 ● Stitch seam when needle thread tension is too strong</p>	<p>→ ● 减弱面线张力 ● decrease the needle thread tension → ● 增大底线张力 ● increase the bobbin thread tension</p>

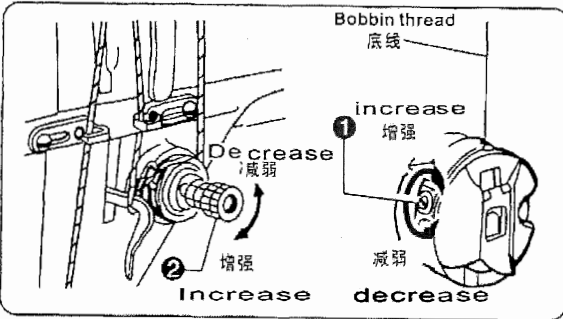

<底线张力> 通过转动梭皮螺钉①调节底线的张力，一般为捏住线

头吊起梭心套，梭芯套能够缓慢地自由落下就可使用了。

<面线张力> 将底线张力调节完后，再调节面线张力更好，会出现正常的线迹。

1. 放下压脚。2. 调节夹线器螺母②。

<Bobbin thread tension>

Adjust by turning the screw ① until the bobbin case drops gently by its own weight while the thread end coming out of the bobbin case is held.

<Needle thread tension>

After adjust the bobbin thread tension, adjust the needle thread tension so that a good, even stitch seam is obtained.

1. Lower the presser foot;
2. Adjust by turning the thread tension nut ②.

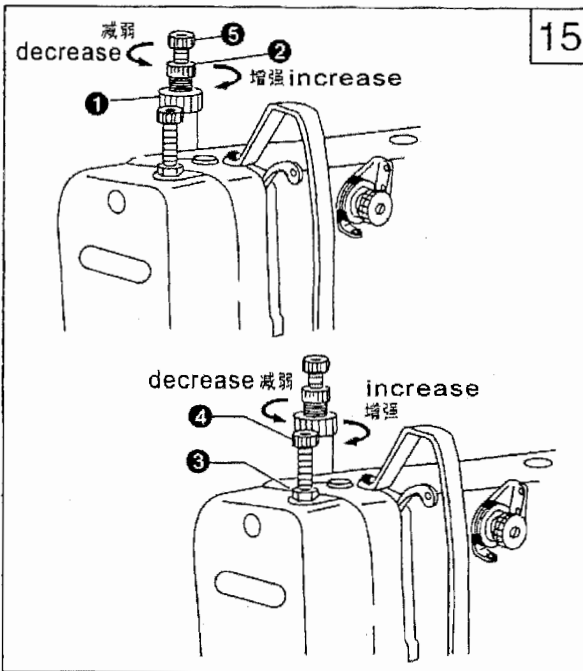

15

17. 调节压脚压力(图15) **Adjusting the presser foot pressure (Fig. 15)**

<调节压脚的壓力> 1. 旋松调压螺钉锁紧螺母①。

2. 转动调压螺钉②来调节压脚压力，在压力不够的情况下，可以转动螺钉⑤来增加压力。

* 在保证缝料不打滑的情况下，压脚的壓力尽可能的弱一些。

3. 拧紧调压螺钉锁紧螺母①。

<调节送料压脚的壓力> 1. 旋松锁紧螺母③。

2. 转动调节螺钉④来调节送料压脚的壓力，顺时针转动调节螺钉④来增大压力，逆时针转动则减小压力。

3. 拧紧锁紧螺母③。

<Adjusting the presser foot pressure>

1. Loosen the lock nut ①;

2. Turn the adjusting screw ② to adjust the pressure of presser foot, if it's not enough, please turn the screw ⑤ to increase the pressure.

* The pressure should be as weak as possible, but strong enough so that the material doesn't slip.

3. Tighten the nut ①.

<Adjusting the walking foot presser>

1. Loosen the nut ③;

2. Turn the screw ④ clockwise to increase the pressure, on the contrary, turn the screw counterclockwise to decrease the pressure;

3. Tighten the nut ③.

18. 调节剪线后线头的长度 (图16)

18. Adjusting the trailing length after thread trimming (Fig.16)

通过转动小夹线螺母 ① 来调节。

- 在剪线的时候, 夹线器松开, 面线只有小夹线器提供的张力。
- 标准面线线头的长度为40~70mm。
- 如果小夹线螺母 ① 旋紧, 那么面线的线头长度就短。

如果小夹线螺母 ① 旋松, 那么面线的线头长度就长。

Turn the nut ① to adjust the trailing length

● At the time of thread trimming, the thread tension mechanism will release and the needle thread tension is only applied by the thread guide ①;

● The standard trailing length for the needle thread is 40-70mm;

● If increase the thread guide tension, the trailing length will be short; if decrease the thread guide tension, the trailing length will be longer.

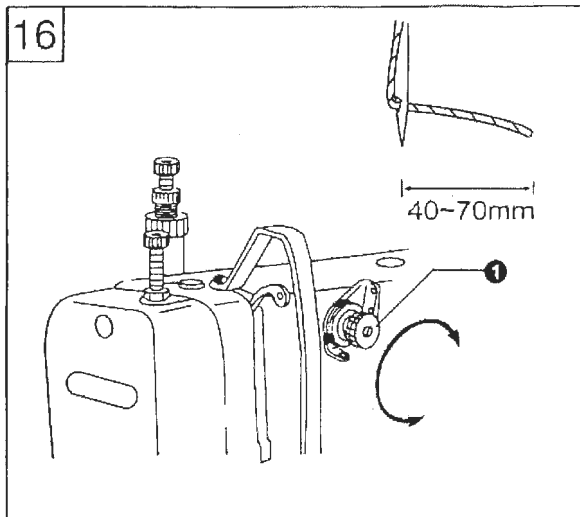

19. 调节挑线簧 (图17)

19. Adjusting the thread tension spring (Fig. 17)

★ 挑线簧的标准位置为: 当压脚 ② 放下时, 大线勾

③ 的上表面至挑线簧 ① 5~8mm

1. 放下压脚 ②。
2. 松开固定螺钉 ④。
3. 转动夹线组件 ⑤ 调整夹线簧的位置。
4. 拧紧固定螺钉 ④。

★ 挑线簧的标准强度为0.3~0.6N。

5. 将面线拉出夹线器 ⑤ 少许, 并用手指按住。
6. 将面线向下拉, 使挑线簧 ① 与大线勾 ③ 上表面一致, 这时就测定挑线簧的强度。
7. 用开刀插入夹线螺钉槽 ⑥ 中, 通过转动开刀来调节挑线簧 ① 的力度。

注意:

当使用测力器 ⑦ 请读取对准红线上的那个数字。

★ The standard position of the thread tension spring ① is 5-8mm above the upper surface of the thread guide ③ when the presser foot ② is lowered.

1. Lower the presser foot ②;
2. Loosen the screw ④;
3. Turn the thread tension bracket ⑤ to adjust the spring position;
4. Tighten the screw ④.

★ The standard tension of the spring is 0.3-0.6N.

5. Push the needle thread with your finger until it is slightly higher than the thread tension bracket ⑤ and so that the upper thread is not pulled out;

6. Pull the needle thread down until the spring ① is at the same height with the upper surface of thread guide ③, and then measure the tension of the spring.

7. Insert a screwdriver into the slot of the thread tension stud ⑥, and turn the stud to adjust the tension of the spring ①.

Note:

If using a tension gauge ⑦ to measure the tension, take the reading from the scale on the side of the red line.

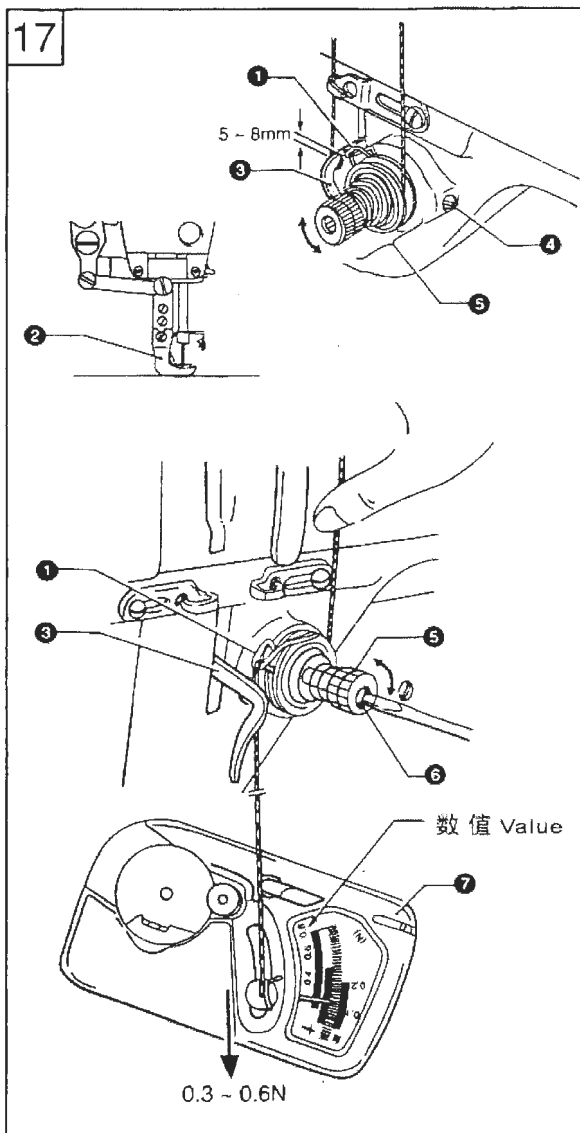

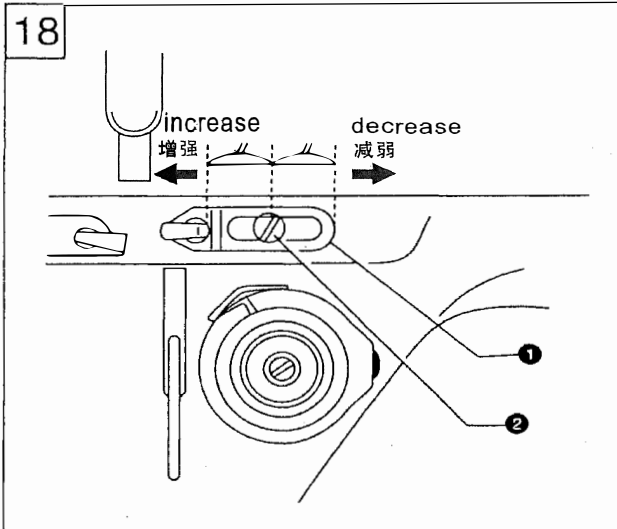

20.调节机壳线勾(图18)

20. Adjusting the upper thread guide(Fig. 18)

机壳线勾①的标准位置是螺钉②处于机壳线勾调节范围的中心位置。

通过松开螺钉②，移动机壳线勾来调节位置。

当缝纫厚料时，将机壳线勾向左移（挑线力将增大）。

当缝纫薄料时，将机壳线勾向右移（挑线力将减弱）。

The standard position of upper thread guide ① is where the screw ② is in the center of the adjustable range of upper thread guide. To adjust the position, loosen the screw ② and move the thread guide.

If stitch the heavy materials, move the thread guide leftward. (To increase the thread take-up tension)

If stitch the light materials, move the thread guide rightward. (To decrease the thread take-up tension)

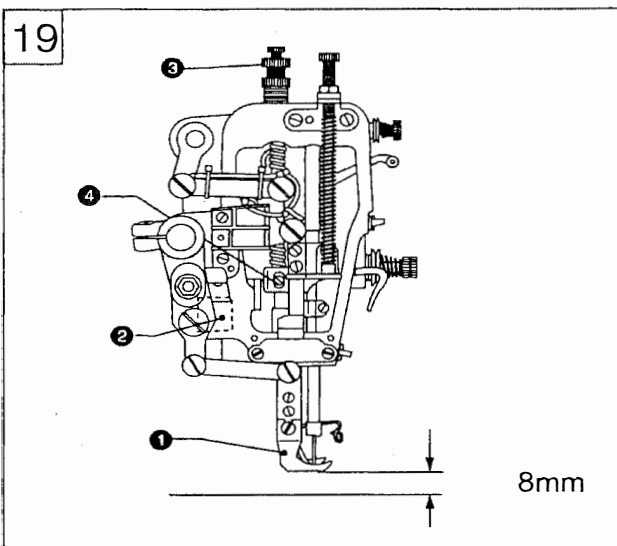

21.调节压脚高度(图19)

21. Adjusting the presser foot height (Fig. 19)

当使用压脚扳手提升压脚时，压脚①的标准提升高度为8mm

1.松开压脚调节螺钉③，使压紧杆及压脚上升。

2.在压脚下放置8mm厚的量块。

3.松开螺钉④上下调整压脚高度。

4.拧紧螺钉④。

The standard height of presser foot ① is 8mm when it is lifted by hand.

1.Loosen the screw ③ to lift the presser bar

2.Put a measurement gauge with 8mm height under the presser foot;

3.Loosen the screw ④ and adjust the height of presser foot;

4.Tighten the screw ④.

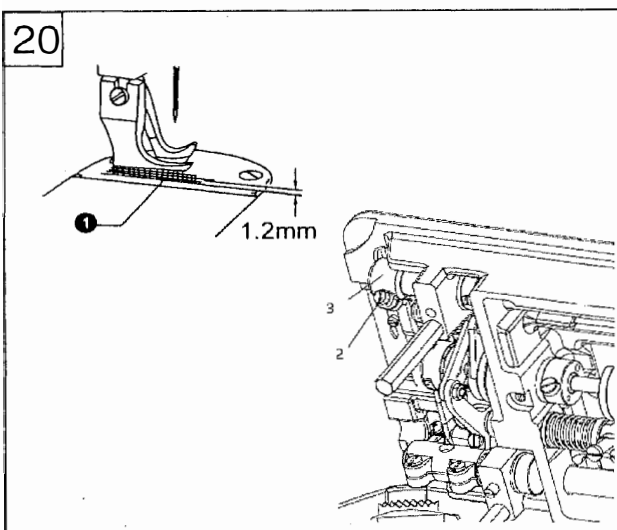

22.调节送布牙高度(图20)

22. Adjusting the feed dog height (Fig. 20)

1.最大针距时，送布牙高出针板1.2mm为标准。

2.松开螺钉②转动抬牙叉③的角度，就可调整送布牙齿的高度。

1.Set the stitch length maximum, when the feed dog ① is at its highest position above the needle plate, the standard height is 1.2mm

2.Loosen the screw ② and turn the feed lifting arm ③ to adjust the height of feed dog.

23. 调节送布牙的角度 (图21)

23. Adjusting the feed dog angle (Fig. 21)

送布牙的标准倾斜角度为：当送布牙高于针板并处于最高位置时，牙架曲柄偏心轴⑤上的凹点标记处于水平位置。

1. 转动上轮使送布牙浮出针板并处于最高位置。
2. 松开牙架曲柄轴螺钉⑦。
3. 根据送布牙的标准角度位置，使凹点标记90°范围内转动调整。

*送布牙前方降低，可以防止布料起皱（图A）。

*送布牙前方抬高，可以防止布料跑偏（图B）。

4. 拧紧牙架曲柄轴螺钉⑦。

送布牙角度调整结束后，重新调节送布牙的高度是必要的。

The standard angle of the feed dog is: when the feed dog is at its highest position above the needle plate, the Mark on the feed bracket shaft is on the horizontal position.

1. Turn the machine pulley to lift the feed dog to its highest position;
2. Loosen the screw ⑦;
3. Turn the feed bracket shaft in the direction of the arrow within a range of 90 with respect to the standard angle position.

* In order to prevent puckering, lower the front of the feed dog (Fig. A)

* In order to keep the materials straight, raise the front of the feed dog (Fig. B)

4. Securely tighten the set screw ⑦.

It's necessary to adjust the feed dog height a gain after this adjustment.

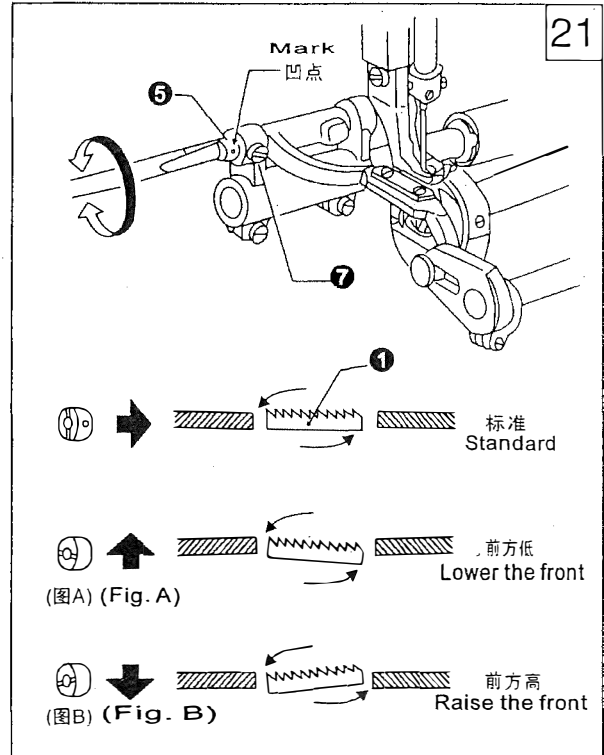

24. 调节倒顺缝针距误差 (图22)

24. Adjusting the difference of stitch length between the forward and backtacking (Fig. 22)

1. 卸下后盖板。
 2. 松开螺钉① 转运针距调节连杆偏心销钉②。
- * 顺时针转：顺缝针距变大，倒缝针距变小。
 - * 逆时针转：顺缝针距变小，倒缝针距变大。

3. 拧紧螺钉①。

1. Remove the rear cover;
2. Loosen the screw ① and turn the connecting stud ②

* Turn the stud ② clockwise, the forward stitch length will be longer and the backtacking stitch length will be shorter;

* Turn the stud ② counterclockwise, the forward stitch length will be shorter and the backtacking stitch length will be longer;

3. Tighten the screw ①.

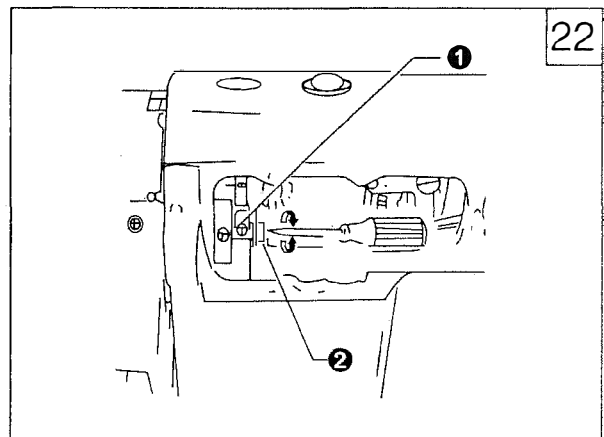

25. 调节松线器的挺线 (图23)

25. Adjusting the tension release (Fig. 23)

压脚在提升范围内，夹线器上的夹线板有一个张开期，挺线的时间可进行调节。调节时，先卸下机头后侧面的橡皮塞，用螺丝刀旋松膝控提升杠杆（左）螺钉①，这时松线凸轮可以左右移动，往右移挺线慢，往左移挺线快。

The opening time of the thread tension discs can be adjusted.

Remove the rubber cap on the rear of arm, and turn the screw ①, then the thread release cam ② can be moved left or right.

Move the cam rightward, the release time will be slow

Move the cam leftward, the release time will be quick.

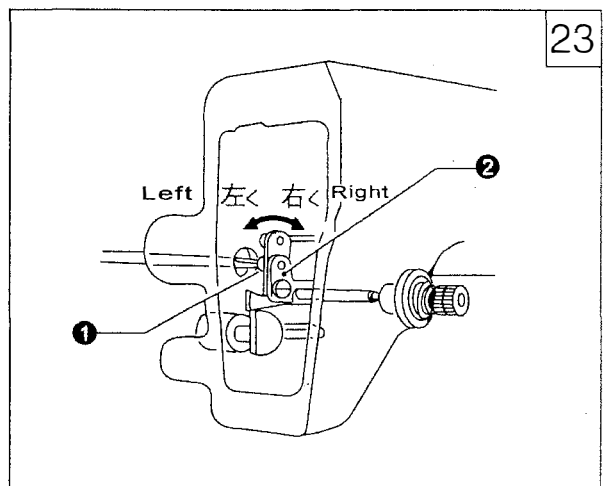

24

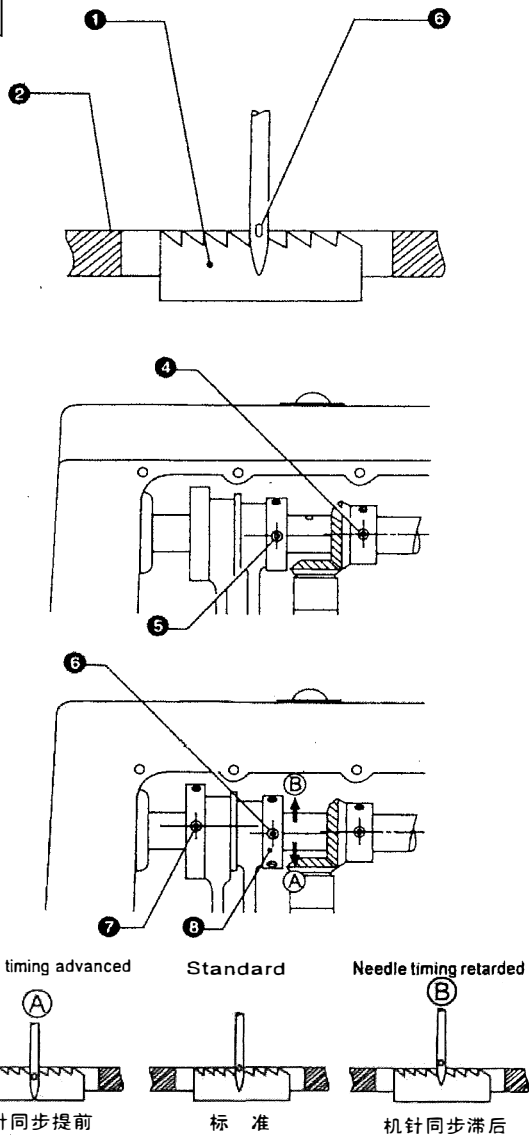

26. 调节机针与送布机构同步(图24)

26. Adjusting the timing of needle and feed mechanism (Fig. 24)

标准位置:

当送布牙从最高位置下降, 机针孔中心③应与针板上表面②、送布牙顶端①在同一水平面上。

调整可以通过调节送布凸轮和抬牙凸轮的安装位置进行。

1. 卸下后盖板。
2. 用左手逆时针转动上轮, 以上轴齿轮第二只固定螺钉④为基准, 抬牙凸轮的第三只固定螺钉⑤中心, 将对齐④中心, 稍微向下偏一点。
3. 继续逆时针转动上轮, 以抬牙凸轮⑤第二只紧固螺钉⑥为基准, 送布凸轮的第三只紧固螺钉⑦中心, 将对齐⑥中心, 稍微向上偏一点。
4. 若要调整为非标准位置, 则先松开抬牙凸轮上三颗螺钉, 再根据(A)或(B)所示方向少许转动偏心凸轮③。

为增加线的张力, 则向(A)方向转动。

为避免机针折弯, 则向(B)方向转动。

5. 调整结束后, 拧紧所有螺钉。

The standard timing is when the feed dog is lowered from its highest position until it is flush with the top of the needle plate ②, and the needle eye ③ is also aligned horizontally with the surface.

Adjust by changing the phases of feed cam and eccentric wheel UD

1. Remove the rear cover
2. Turn the machine pulley in reverse direction, set the second screw ④ on the gear of upper shaft as reference mark, make the third screw ⑤ of eccentric wheel UD slightly lower than the reference mark screw ④;
3. Continue to turn the machine pulley, set the second screw ⑥ of eccentric wheel UD as reference mark, make the third screw ⑦ of feed cam slightly higher than the reference mark screw ⑥.

4. If need a non-timing position, loosen the three screws of eccentric wheel UD, adjust the eccentric cam ③ in the direction of arrow (A) or (B)

To increase the tension of thread, turn the eccentric cam ③ to direction (A)

To avoid the needle bent, turn the eccentric cam ③ to direction (B)

5. After adjustment, tighten all of the screws.

27. 调节旋梭油量(图25)

27. Adjusting the rotary hook lubrication amount (Fig. 25)

放倒机头, 转动油量调节螺钉①来调节油量大小。

Tilt back the machine head, and turn the oil adjustment screw ① to adjust the hook oiling amount.

25

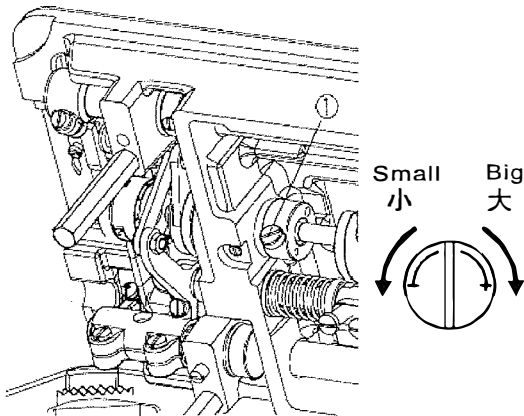

28.调整针杆高度与旋梭同步 (图26)

28. Adjusting the height of needle bar and the timing with hook (Fig. 26)

当针杆降至最下位置时，针杆①最上面的刻线标记应与针杆下套②的下端面一致。

- 1.转动上轮，使针杆降至最下位置。
- 2.取下橡皮塞③。
- 3.松开螺钉④，然后上下移动针杆①来调节它的位置。
- 4.拧紧螺钉④。
- 5.塞上橡皮塞③。

使针杆①从最下位置上升，当针杆①上数第二条刻线标记⑥对准针杆下套②的下端面时（如图所示），旋梭的梭尖⑤应对准机针⑥的中心。

- 1.转动上轮使针杆①从最低位置上升，直至上数第二条刻线标记⑥对准针杆下套的边沿。

*当针杆上升2.4mm时，针眼上限与旋梭梭尖之间的距离为1.3~1.8mm。

- 2.松开螺钉⑦，然后将梭尖对准机针⑥的中心。

此时旋梭尖与机针的侧面间隙为0.05mm。

- 3.拧紧螺钉⑦。

When the needle bar ① is at its lowest position, the top reference line (A) on the needle bar should be aligned with the bottom edge of the needle bar bush ②.

1. Turn the machine pulley to lower the needle bar to its lowest position;
2. Take out the rubber cap ③;
3. Loosen the screw ④, and move the needle bar ① to proper position;
4. Tighten the screw ④;
5. Close the rubber cap ③.

Lift the needle bar ① from the lowest position, when the second reference line (B) on the needle bar is aligned with the bottom edge of the hook should be aimed at the center of needle ⑥.

1. Turn the machine pulley to raise the needle bar ① from its lowest position until the reference line (B) is aligned with the bottom edge of the needle bar bush ②

* When the needle bar moves up 2.4mm, the clearance between the upper of needle hole and the hook tip should be 1.3-1.8mm

2. Loosen the screw ⑦, and make the hook tip aimed at the center of needle ⑥, the clearance between the hook tip and needle should be 0.05mm
3. Tighten the screw ⑦.

29.调节油泵供油 (图27)

29. Adjusting the oil pump (Fig. 27)

当低速运转时，观察油窗，无喷油现象时，请转动供油调节板①，将其盖住油孔②。

If the oil is not circled observed from the oil gauge window at a lower sewing speed, turn the oil adjustment plate ① to cover the oil hole ②.

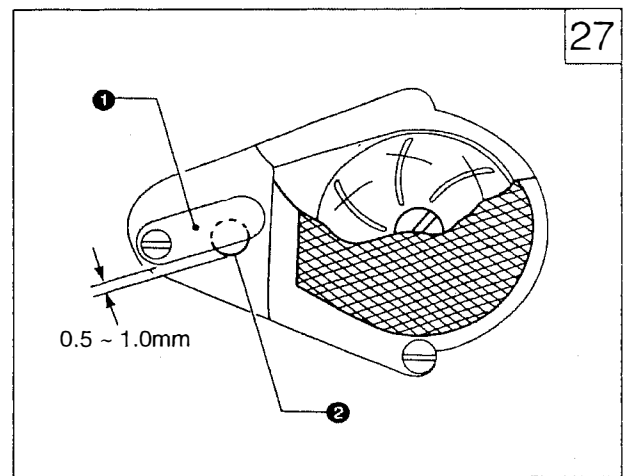
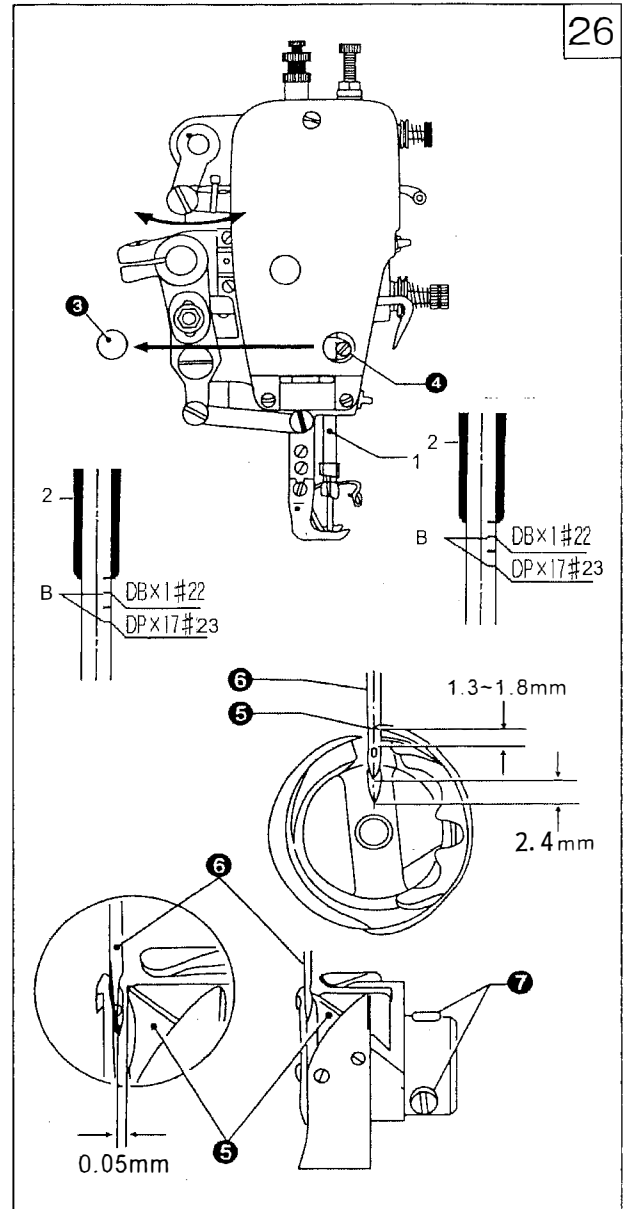

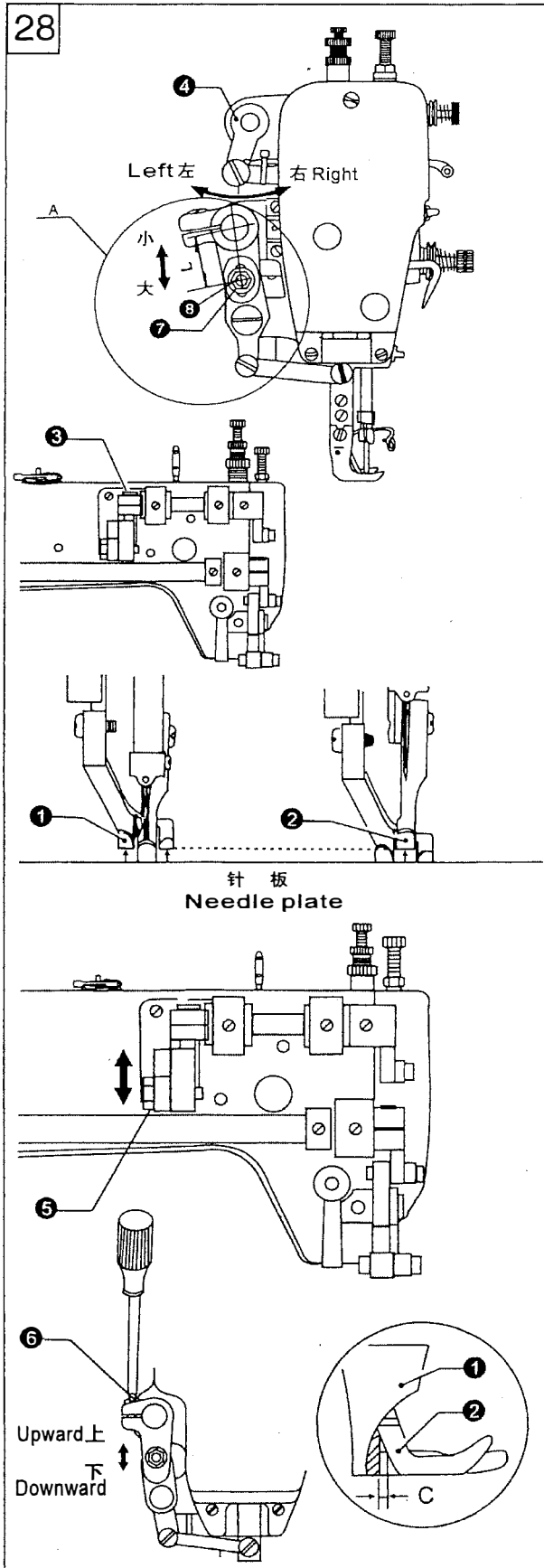

30. 调节摆压脚与小压脚交替提升量(图28)

30. Adjusting the lifting amount of presser feet (Fig. 28)

1. 摆压脚及小压脚的垂直方向运动:

★ 摆压脚及小压脚是交替式的上下运动。

★ 摆压脚及小压脚上升高度一般是相同的或是小压脚的上升高度略低一些。

将挑线杆置于最下位置, 放下压脚扳手, 松开螺钉

③使压脚升降前曲柄左, 右移动来调节交替提升量。

(右移: 两压脚交替提升量趋于相同)
左移: 小压脚的提升量减小

1. Vertical movement of presser foot and walking foot

★ The walking foot ① and presser foot ② move vertically one after another

★ Usually the stroke of walking foot and presser foot is same or the stroke of presser foot is slightly lower.

Place the thread take-up lever at the lowest position, and lower the presser bar lifter, loosen the screw ③ and move the upper feed lifting cam ④

Move it rightward to make the stroke of two feet be equal

Move it leftward to make the stroke of presser foot be smaller.

2. 摆压脚及小压脚总提升量的调节:

根据缝料的不同要改变摆压脚, 小压脚的提升量。

先将偏心轮连杆螺钉⑤旋松, 然后上、下移动来调节该螺钉与压脚升降轴的中心距, 中心距调小, 则各自的提升量都增加。

2. Adjusting the lifting amount of presser feet
Adjust the lifting amount of two feet to match the materials to be sewn.

Loosen the screw ⑤, and move the screw upward to increase the lifting amount or move the screw downward to decrease the lifting amount.

3. 摆压脚、小压脚前后方向间隙的调节:

★ 为了在缝纫过程中, 使摆压脚槽的前端与小压脚后端

面不碰撞, 必须保持适当的间隙C (3mm左右)。

旋松摆压脚前曲柄螺钉, 然后上、下转动压脚摆动轴⑥来进行调节。

3. Adjusting the forward/backward clearance of the two feet

To keep the front groove of walking foot not strike the rear of the presser foot, the clearance of C must be kept about 3mm.

Loosen the screw of feed arm R, and then turn the feed rock shaft ⑥ to adjust.

4. 摆压脚量的调节 (见A部)

★ 送布牙送料量与摆压脚送料量之间的标准比率为1:1 (同步送料)。

摆压脚的送料量可根据缝料不同进行调整, 松开螺母⑦, 上下移动摆压脚滑块⑧来调节。

(向上: 减小中心距L, 摆压脚送料量减小)
向下: 增大中心距L, 摆压脚送料量增大)

4. Adjusting the feed amount of walking foot (Fig. A)

★ The standard ratio of feed amount between feed dog and walking foot is 1:1

The feed amount of walking foot can be adjusted to suit for the materials to be sewn.

Loosen the nut ⑦, and move the slide block ⑧

Upward: decrease the distance L to make the feed amount be smaller

Downward: increase the distance L to make the feed amount be larger

31. 剪线装置的调整 Adjusting the trimming mechanism

1. 剪线装置 (结构见图29) 1. Trimming mechanism (Fig. 29)

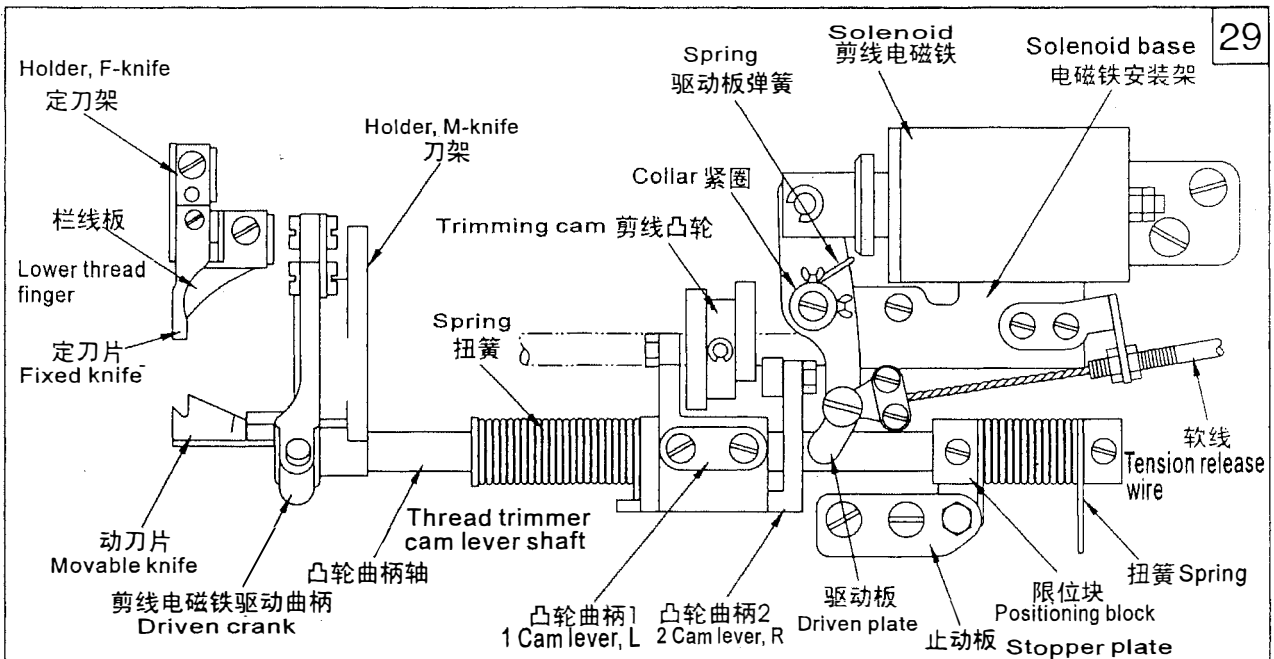

2. 定刀片与动刀片的关系: (见图30)

- (1) 定刀片①与动刀片②的位置应保证0.3mm。
- (2) 可以如图所示进行调整定刀座或定刀片的位置。
- (3) 移开旋梭定位勾, 安装定刀座。

2. The relation between fixed knife and movable knife (Fig. 30)

- (1) The clearance between fixed knife ① and movable knife ② should be 0.3mm
- (2) Adjust the position illustrated by the Fig. 35
- (3) Move the bobbin case opener and adjust the holder of fixed knife.

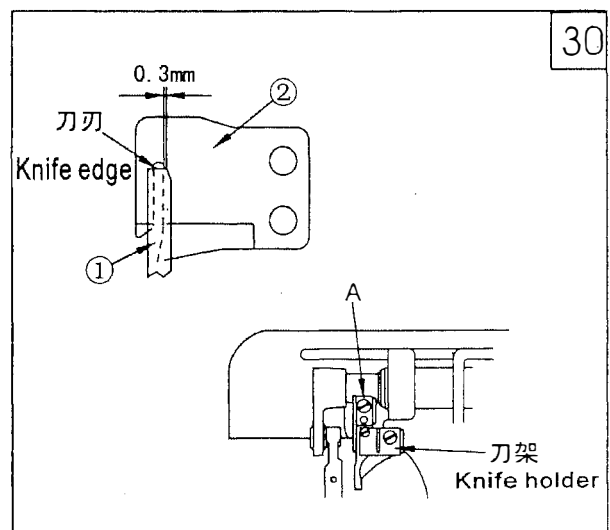

3. 凸轮曲柄轴 (见图31)

- (1) 装配时, 将凸轮曲柄轴①最先装在底板上。
- (2) 凸轮曲柄1必须如图所示安装, 固定在凸轮曲柄轴①上的平面处。
- (3) 轻轻转动凸轮曲柄轴①, 将限位块②安装在凸轮曲柄轴①上的平面处。

3. Thread trimmer cam lever shaft (Fig. 31)

- (1) Install the shaft ① on the machine bed first;
- (2) Install the cam lever L on the shaft ① as illustrated;
- (3) Slightly turn the shaft ①, and install the positioning block ② as illustrated.

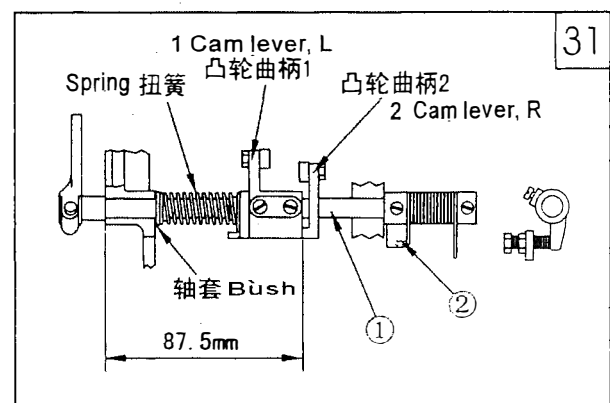

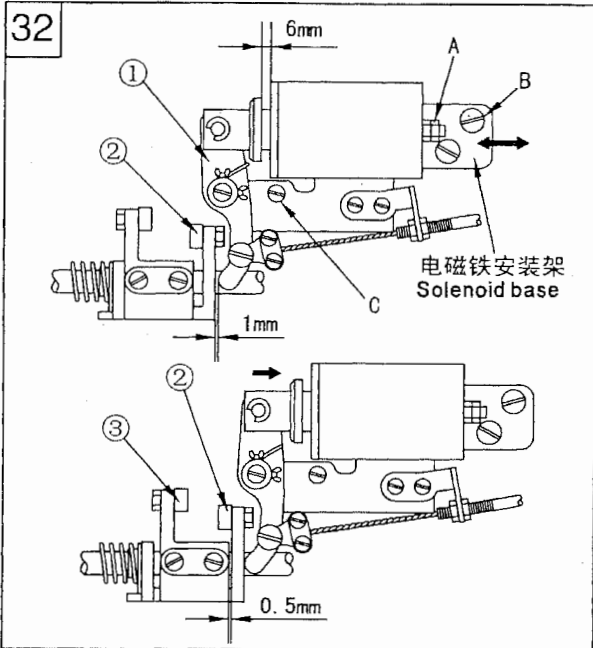

4、安装剪线电磁铁 (见图32)

(1)剪线电磁铁的行程:

- a.标准的行程为6.0mm。
- b.通过调节螺母A来调整行程。

(2)安装剪线电磁铁:

- a.剪线电磁铁用螺钉B和C来固定。
 - B.在安装时必须保证驱动板1与凸轮曲柄2之间的间隙1mm
 - C.电磁铁工作时, 凸轮曲柄3与凸轮曲柄2之间会有0.5mm的间隙, 这是标准的情况。
- 如需调整可以如图26所示箭头方向滑动电磁铁安装架。

4.Installing the trimming solenoid (Fig. 32)

(1)The stroke of solenoid

- a. The standard stroke is 6.0mm
- b. Turn the nut (A) to adjust the stroke

(2)Installing the solenoid

- a.Fixed the solenoid by the screws B and C;
- b. Be sure to keep the clearance between the driven plate ① and cam lever R ② 1mm;
- c. When the solenoid is active, there should be a 0.5mm clearance between the cam lever L ③ and cam lever R ②. If need to adjust, please move the solenoid base shown by the arrow.

5、安装剪线凸轮 (见图33)

(1)在挑线杆位于最低点时。

(2)将剪线电磁铁开动向前旋转剪线凸轮1直到接触滚柱, 然后固定凸轮。

(3)剪线电磁铁关闭, 使凸轮曲柄2回复到原始位置, 这样凸轮与滚柱端面将会产生0.5-1.0mm的标准间隙。

5.Installing the trimming cam (Fig. 33)

(1) When the joystick is at the lowest point.

(2)Set the solenoid active and turn the trimming cam ① until the cam is touched with the roller, then fix the cam;

(3)Set the solenoid inactive and make the cam lever ② restore to the original position, there should be a 0.5-1.0mm clearance between cam and roller.

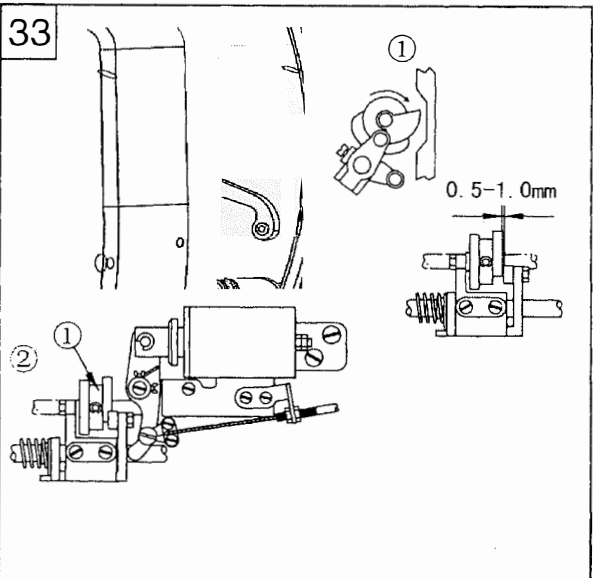

34

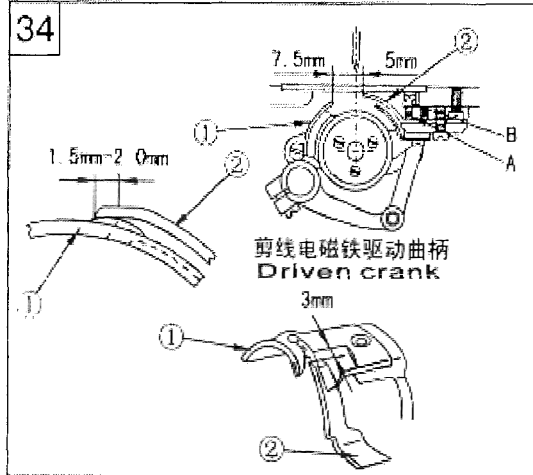

6. 刀片的调整 (见图34)

(1) 动刀片与定刀片的关系:

如图所示, 动刀片 1 与机针中心的距离为 7.5mm, 定刀片 2 与机针中心的距离为 5mm

(2) 刀片的调整:

开动电磁铁, 启动机器。这样, 剪线凸轮会使动刀片 1 右旋转。当动刀片 1 左移动到其最远位置时, 与定刀片 2 的间隙为 1.5-2.0mm。

(3) 剪线电磁铁的调整:

A. 如果剪线情况不良, 尤其当线较粗时, 只需增加剪线压力即可。

B. 剪线压力可如下所述进行调整: 松开螺母 B, 通过调节螺钉 A 来调节螺母 B。

6. Adjusting the knives (Fig. 34)

(1) The relation between fixed knife and movable knife

The clearance between movable knife ① and needle center is 7.5mm, and the clearance between fixed knife ② and needle center is 5mm.

(2) Set the solenoid active, the movable knife ① will turn rightward driven by the trimming cam. When the movable knife ① moves to its left furthest position, the clearance between two knives ① and ② should be 1.5-2.0mm

(3) Adjusting the trimming solenoid

A. If the thread trimming not smoothly, especially the thick thread used, just need to increase the trimming pressure;

B. Adjusting the trimming pressure: loosen the nut B, adjust the screw A to get the reasonable pressure.

32. 清扫(图35) 38. Clean (Fig. 35)

1. 抬起压脚。
 2. 拧开两螺钉 ①, 然后卸下针板 ②。
 3. 使用软毛刷对送布牙进行清扫。
 4. 装上针板 ② 及拧紧两螺钉 ①。
1. Raise the presser foot;
2. Remove the two screws ① and needle plate ②;
3. Clean the feed dog with a soft brush;
4. Install the needle plate ② by two screws ①.
5. 缓慢转动上轮, 观察机针是否落入针板孔的中心位置。
- ★If not
- Check if the needle is bent
 - Loosen the screw ①, and reinstall the needle plate ②
6. 转动上轮将机针上升至针板以上, 然后观察机针针尖是否钝挫, 如果钝挫则更换机针。
 7. 放倒机头。
 8. 卸下梭芯套 ④。
 9. 用软布将旋梭中的灰尘擦除干净, 并检查旋梭是否被损坏。
 10. 将梭芯从梭芯套中拿出, 用布将梭芯套擦干净。
 11. 将梭芯放入梭芯套中, 然后将梭芯套装入旋梭中。
 12. 清除油泵滤网 (A) 上的尘屑。
6. Turn the machine pulley and lift the needle above the needle plate, check if the needle tip is blunt, if yes, change a new one.
7. Tilt back the machine head
8. Remove the bobbin case ④
9. Clean the hook with a soft cloth and check if the hook is worn out
10. Take out the bobbin from the bobbin case, and clean the bobbin case with a soft cloth
11. Insert the bobbin into the bobbin case and place the bobbin case back into the machine
12. Clean the dust on the filter (A) of oil pump.

35

